



***Facility Study
For
Generation Interconnection
Request
GEN-2007-005***

***SPP Tariff Studies
(#GEN-2007-005)***

March 2010

Summary

Southwestern Public Service Company (SPS) performed the following Study at the request of the Southwest Power Pool (SPP) for Generation Interconnection request Gen-2007-005. The request for interconnection was placed with SPP in accordance SPP's Open Access Transmission Tariff, which covers new generation interconnections on SPP's transmission system.

Pursuant to the tariff, Southwestern Public Service Company was asked to perform a detailed Facility Study of the generation interconnection request to satisfy the Facility Study Agreement executed by the requesting customer and SPP.

Interconnection Customer Interconnection Facilities

The Interconnection Customer will be responsible for the 115kV transmission line from the point of interconnection to its 115/34.5kV substation that will contain its 115/34.5kV transformer(s) and wind turbine collector feeders. In addition, the Customer will be required to maintain a +/- 99% power factor at the point of interconnection (Pringle Interchange 115kV substation). Using the studied Furhlander wind turbines, additional capacitors may be necessary.

Transmission Owner Interconnection Facilities and Non Shared Network Upgrades

Per the following Facility Study, the Interconnection Customer is responsible for \$32,180 of Transmission Owner Interconnection Facilities and \$3,892,834 of non shared Network Upgrades.

Shared Network Upgrades

The GEN-2007-005 Interconnection Customer is included in the 1st Cluster Study approved in FERC Docket #ER09-262. The Interconnection Customer's shared upgrade costs are \$42,669,797. This cost is subject to change depending upon the Facility Study for the shared network upgrades. This cost is also subject to change for restudies conducted by the Transmission Provider in response to the higher queued customers or other customers in the 1st Cluster that withdraw their interconnection request or suspend, terminate, or request unexecuted filings of their LGIAs.

The in service date for the interconnection request may also be delayed depending upon the in service date of the shared network upgrades.



**Facilities Study For
Southwest Power Pool (SPP)**
200 MW Wind-Generated Energy Facility
Hutchinson County, Texas
SPP #GEN-2007-005

March 5, 2010

Xcel Energy Services, Inc.
Transmission Planning

Executive Summary

The Interconnection Customer in 2007 requested the interconnection of a wind energy facility located in Hutchinson County, Texas to the Southwestern Public Service Company (SPS), transmission network. SPS is a New Mexico Corporation and wholly owned subsidiary of Xcel Energy Inc. This facility has a net capacity of 200 MW. The Interconnection Customer's facility will connect to the existing SPS Pringle Interchange located approximately twenty-two (22) miles north of Borger, Texas. The Interconnection Customer's expected commercial operation date is December 6, 2010 and the requested back-feed date is September 6, 2010.

The Southwest Power Pool (SPP) evaluated the request to interconnect the wind farm facility to the SPS transmission system in a System Impact Re-Study (SIRS) GEN-2007-005 completed in January 2010. The interconnection request was studied using eighty (80) Furhlander FL 2500-90 wind turbines rated at 2.5 MW each for a total output of 200 MW at their substation, which will have two (2) 75/100/125 MVA 115/34.5 kV transformers in parallel. The Interconnection Customer is required to build 115 kV transmission lines from their substation wind farm facility to the SPS Pringle Interchange 115 kV bus. The Interconnection Customer is required to provide 25 MVARs of capacitance at the point of interconnection and to maintain a Power Factor of 0.992 lagging at the Point of Interconnection (POI), based on SPP's SIRS for Cluster #1 for Group 2 Table 4-4.

SPS requires that all construction for this request be in compliance with the latest revision of the Xcel Energy Interconnection Guidelines for Transmission Interconnection Producer-Owned Generation Greater than 20 MW, Version 3.0 dated Dec 31, 2006, and is available at (http://www.xcelenergy.com/XLWEB/CDA/0,3080,1-1-1_16699_24407-1428-0_0_0-0,00.html). This document describes the requirements for connecting new generation to the Xcel Energy transmission systems including technical, protection, commissioning, operation, and maintenance. SPS will also require that the Interconnection Customer be in compliance with all applicable criteria, guidelines, standards, requirements, regulations, and procedures issued by the North American Electric Reliability Corporation (NERC), Southwest Power Pool (SPP), and the Federal Energy Regulatory Commission (FERC) or their successor organizations.

The Interconnection Customer is responsible for the cost of the Interconnection Facilities, installation of the 25 MVARs of capacitance and any Direct Assigned Interconnection Facilities; inclusive of all construction required for the 115 kV transmission line from the Interconnection Customer's substation to the SPS Pringle Interchange.

As for this request (GEN-2007-005), it is anticipated that the entire process of adding the new 115 kV line terminal at Pringle Interchange for the acceptance of the wind farm facility output, will require approximately 24 months to complete after an Interconnection Agreement is signed and an authorization to proceed is received.

The cost of these upgrades, inclusive of the Interconnection Customer's cost for the interconnection of this wind farm facility, is shown below in Table 1, with the detailed description of the cost shown in Table 3.

Table 1, Cost Summary¹

	Interchange
Network Upgrades:	\$3,892,834
Interconnection Facilities ² :	\$ 32,180
Total:	\$3,925,014

¹ The cost estimates are 2009 dollars with an accuracy level of ±20%.

² This is a direct assigned cost to the Interconnection Customer.

General Description of SPS Facilities³

1. **Construction of New Line Terminal:** See Appendix A, **Figure A- 1** for general vicinity location map.
 - 1.1. **Location:** SPS will add 9-new 115 kV breakers for 6-line terminals at the existing SPS Pringle Interchange. Appendix A,
 - 1.2.
 - 1.3.
 - 1.4.
 - 1.5.
 - 1.6.
 - 1.7. **Figure A- 2** shows the one-line of the new 115 kV breaker and a half bus design, while Appendix A, **Figure A-3** shows typical elevation view of the Point of Interconnection (POI).
 - 1.8. **Bus Design:** The new 115 kV breakers will replace the existing 115 kV main bus at Pringle Interchange to accommodate the output from the wind energy facility. The existing bus design at Pringle Interchange is a main bus design and will be replaced with 9-115 KV breakers shown in Appendix A,
 - 1.9.
 - 1.10.
 - 1.11.
 - 1.12.
 - 1.13. **Figure A- 2.**
 - 1.14. **Line Terminals:** The 115kV lines and static wire terminals will be designed to accommodate 2,000 pounds per phase conductor at maximum tension, with a maximum 15-degree pull off from normal.
 - 1.15. **Control House:** The existing control house will accommodate the new metering, protective relaying and control devices, terminal cabinets, and any fiber-optic cable terminations, etc. for the new 115kV line breaker terminals.
 - 1.16. **Security Fence:** The existing security fence shall be extended if required when the new bays are added for the new 115 kV line terminals.
 - 1.17. **Ground Grid:** The existing ground grid shall be extended to accommodate the additional bay required for the new line terminal per ANSI/IEEE STD 80-1986, with our standard 4/0 copper ground mesh on 40-foot centers with ground rods and 20-foot centers in corners and loop outside of fence.

³ All modifications to SPS facilities will be owned, maintained and operated by SPS.

- 1.18. **Site Grading:** Company contractor, per company specifications, will perform any site grading and erosion control to accommodate the new line terminal. Soil compaction shall be not less than 95% of laboratory density as determined by ASTM-D-698.
- 1.19. **Station Power:** The existing switching station power, provided from the local distribution system, will be utilized.
- 1.20. **Relay and Protection Scheme:** The new 115 kV breaker line terminals primary protection to the interconnection customer 115 kV transmission line will use line current differential relaying over optical fiber installed in the static of the customer's 115 kV transmission line. Secondary relaying will use mirrored bit, Permissive Overreaching Transfer Trip (POTT) over the optical fiber. An SEL 311L and an SEL 321-1 will be used as primary and secondary relays, respectively. An SEL 279H-2 relay will be installed; however no automatic re-closing scheme will be used. The SEL 279H-2 will be used for line/bus SCADA closing conditions for the 115 kV breaker. Also, a SEL 501-0 will be used for breaker failure. Relaying will have to be modified for wind generation.

An SEL DTA-2 will display the bus voltage, GCB amps, MW, MVAR, and fault location. An SEL 2020 will be installed for relay communications and other functions as required.

- 1.21. **Revenue Metering:** On the proposed SPS Pringle Interchange 115 kV line terminal to the Interconnection Customer's substation, an individual billing meter will be installed along with an ION 8400 meter unit, ANSI C12.1 accuracy class 0.2 (3-PT's IEEE C57.13 accuracy class 0.3 and 3 CT's IEEE C57.13 accuracy class 0.15) for full 3 phase 4-wire metering. Also installed for the metering units will be 3-PT's and 3-CT's for full 3-phase 4-wire metering. There will be two meters per line terminal: one will be primary and the other will be back up, each will have full 4 quadrant metering. Pulses out of the primary billing meter will be sent via SCADA to the Transmission Owner's Control Center in Amarillo, Texas.
- 1.22. **Disturbance Monitoring Device:** Disturbance-monitoring equipment (DFR), capable of recording faults, swings, and long term trending, will be installed to monitor and record conditions in the substation and on the transmission lines. The disturbance equipment shall also be equipped with a GPS time synch clock. This equipment will have communication capability with a dedicated communication circuit. The disturbance equipment will have its own dedicated dial-up communications telephone circuit.
- 1.23. **Remote Terminal Unit (RTU):** The existing RTU will be utilized to accommodate the new 115 kV line terminal at Pringle Interchange. SPS will provide and install if needed additional RTU cards for metering and telemetry as required by the latest Xcel Energy Interconnection Guidelines. The direct cost will be charged to the Interconnection Customer.
- 1.24. **Communications:** Existing telephone and data circuit at Pringle Interchange to the Amarillo Control Center will be utilized. ***It is the Interconnection Customer's responsibility to make arrangements with the local phone company to provide telephone circuits to the relay communication equipment and disturbance-monitoring equipment at Pringle Interchange and to their wind farm facility. Prior to***

any construction the Interconnection Customer is required to contact the SPS substation-engineering department for all details.

A schematic outlining the proposed communications is provided below:

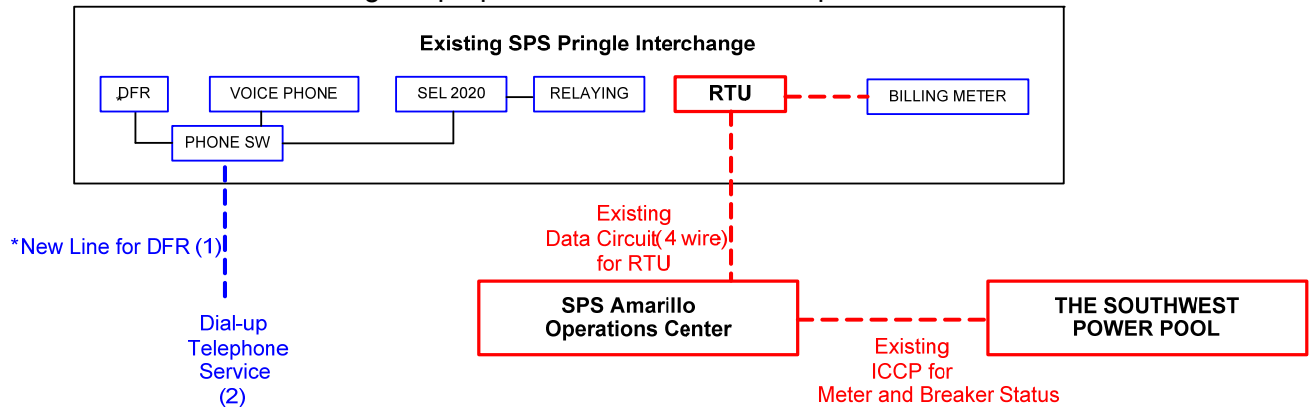

The Interconnection Customer shall be responsible for providing fiber optic communication circuit installed in their overhead transmission line static wire for protective relaying from the customer substation to the existing Pringle Interchange indicated in Section 1.9.

2. Transmission Work:

- 2.1. The Interconnection Customer will construct, own, operate, and maintain any customer owned 115 kV transmission line from the Interconnection Customer's substation to the Interconnection Point at SPS Pringle Interchange as shown in Appendix A, Figure A- 1. **The SPS transmission design group prior to any construction by the Interconnection Customer or its contractor on any customer 115 kV transmission lines, or doing work in close proximity to any SPS transmission line, will require an engineering review of the customer's design. It is the Interconnection Customer's responsibility to initiate the design review in a timely manner before construction of any transmission line begins. If the review has not been made or the design at any of the aforementioned locations is deemed inadequate, the crossing(s) and or termination into the SPS Pringle Interchange will be delayed until the matters are resolved. SPS will not be held responsible for these delays.**

3. Right-Of-Way and Permits:

- 3.1. **Permitting:** Permitting for the construction of a new 115 kV line terminal at Pringle Interchange is not required from the Public Utility Commission in the State of Texas. The interconnection customer will be responsible for any permitting and right of way of their substation and the 115 kV transmission line from their substation to the Interconnection Point at Pringle Interchange.

4. **Construction Power and Distribution Service:** It is the sole responsibility of the Interconnection Customer to make arrangements for both construction and station power, which may be required for the Interconnection Customer's wind farm facility. **Additionally, if the Interconnection Customer's substation(s) and/or construction site(s) are located outside of the SPS service area, SPS cannot provide station power (retail distribution service) and the Interconnection**

Customer needs to make arrangements for distribution service from the local retail provider.

5. Project and Operating Concerns:

5.1. Close work between the Transmission group, the Interconnection Customer’s personnel and local operating groups will be imperative in order to meet any in-service date that has been established.

5.2. It is understood that the 25 MVAR Capacitor Bank will be installed at the Interconnection Customer’s 34.5 bus side to avoid voltage spikes on the 115 kV that adversely affects the Xcel Energy transmission system. The Interconnection customer will be required to switch the 25 MVAR capacitor bank in stages of 20 MVAR or less. This is required to maintain acceptable dynamic voltage rise as per latest revision of the Xcel Energy Interconnection Guidelines for Transmission Interconnection Producer-Owned Generation Greater than 20 MW, Version 3.0 dated Dec 31, 2006, and is available at (http://www.xcelenergy.com/XLWEB/CDA/0.3080.1-1-1_16699_24407-1428-0_0_0-0.00.html).

6. **Fault Current Study:** The available fault current at the interconnection location, without any contribution from the wind farm facilities, is shown in Table 2 below.

Table 2, - Available fault current at Point of Interconnection Location

Short Circuit Current Availability at Pringle Interchange without contribution from Wind Farm Facility (GEN 2007-005)				
Fault Location	Fault Current (Amps)		Impedance (Ω)	
	Line-to-Ground	3-Phase	Z^+	Z^0
115 kV Bus	3,389	10,584	1.010 +j6.191	1.038 +j6.979

Estimated Construction Costs

The projects required for the interconnection of this 200 MW Wind Farm facility consist of the projects summarized in the table below.

Table 3, Required Interconnection Projects

Project	Description	Estimated Cost ⁴
Network Upgrades		
1	Disturbance Monitoring Device	\$ 51,346
2	Transmission Line Work	\$ 0
3	Rebuild 115 kV bus to breaker and a half.	\$3,841,488
4	Right of Way	\$ 0
Subtotal:		\$3,892,834
Transmission Owner Interconnection Facilities (at the Interconnection Customer's expense)		
5	Communications ⁵	\$ See footnote
6	Remote Terminal Unit (RTU)	\$ 4,500
7	Revenue metering	\$ 24,000
8	115 kV Line arrestors	\$ 3,680
Subtotal:		\$ 32,180
Total Cost:		\$3,925,014

Engineering and Construction:

An engineering and construction schedule for the installation of the 9-115 kV breakers 6-line terminals is depicted below and is estimated at approximately 24 months. Other factors associated with clearances, equipment delays and work schedules could cause additional delays. The estimated time (12 months) is applicable after all required agreements are signed and internal approvals are granted.

All additional cost for work not identified in this study is the sole responsibility of the Interconnection Customer unless other arrangements are made.

⁴ The cost estimates are 2009 dollars with an accuracy level of $\pm 20\%$.

⁵ It is the Requester's responsibility to provide both the data circuit and both dial-up telephone circuits, see Section 1.24.

Appendix A



Figure A- 1 Approximate location of proposed Wind Farm Facility and Interconnection Customer 115 KV Transmission Line⁶

⁶ 115 kV customer transmission line shown does not represent actual route.

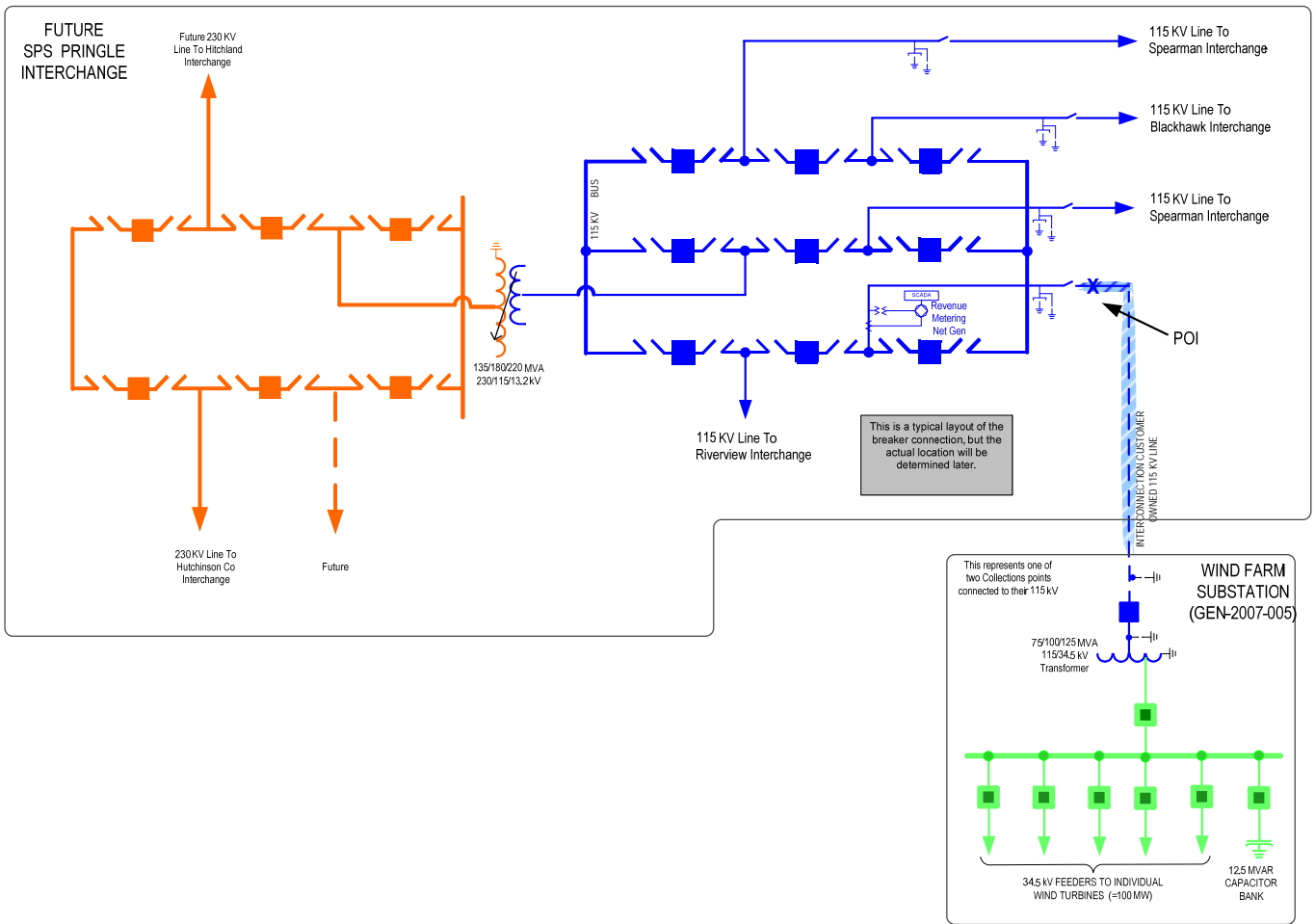

Figure A- 2 One-line Diagram of Pringle Interchange

**CUSTOMER SHALL PROVIDE
ALL MATERIAL FOR DEAD
ENDING PHASES AND STATIC
TO 115 kV DEAD END TOWER.
DEMONSTRATION PURPOSES.**

Customer's Responsibility

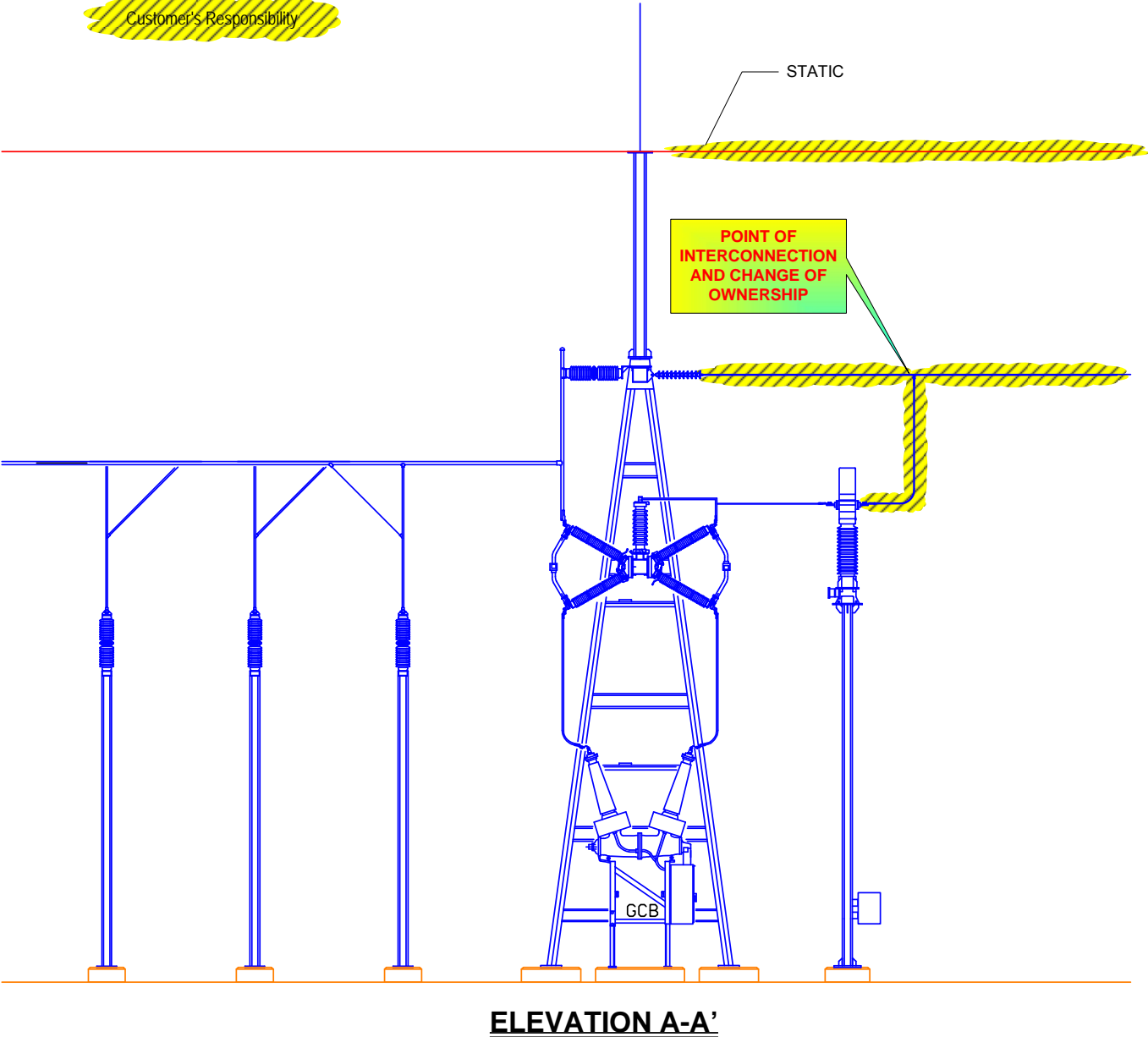

Figure A-3 Point of Interconnection & Change of Ownership (Typical)

– END OF REPORT –